



**TAP REMOVER SPECIALIST !**



## Luoyang Xincheng Precision Machinery Co., Ltd

ADD: No.256, Tanggong East Road, Luoyang, China

ZIP CODE: 471002

TEL: +86-0379-63512276

FAX: +86-0379-69960770

EMAIL: [tapremover@lyxc.com](mailto:tapremover@lyxc.com)

Website: [www.brokentapremover.com](http://www.brokentapremover.com)

## HIGH POWER PORTABLE EDM

# SFX-4000B

## OPERATION MANUAL





## Contents

Contents.....	1
Profile.....	2
Tech. Specification.....	3
I. Functions and Features.....	4
II. Components of EDM.....	4
III. Operation Notices.....	7
1. Operating Steps.....	7
2. Processing Steps.....	7
3. Usage of Up " ↑ " and Down " ↓ " Button.....	8
4. Usage of Reset Key.....	8
5. Usage of Vibration Button.....	8
6. Shutdown Procedures.....	8
IV. Attentions.....	9
V. Failures and Solutions.....	11
VI. Selection of Electrode Materials and Work Liquid.....	12
VII. Selection of Electrode Size.....	13
VIII. How to Remove Broken Tap, Drill, Screw etc.....	14
IX. Selection of Stepper.....	15
X. How to Clamp Electrode to Avoid Work Piece Being Damaged.....	15
XI. The Schematic Diagram of EDM Processing Method.....	15
Customer Service.....	18

## Customer Service

With company spirit "High Quality, Excellent Service, Striving for Development" and company concept "Quality Product, Competitive Price, Considerate Service", we promise to you responsibly and publicly:

Warranty Terms:

1. Our product will have to go through a thorough quality exam process to ensure that our devices won't have any glitch before delivery.
2. The warranty period is usually around one year and within this time frame, if there are any technical problems, we would repair them for free including the new parts that needed for the repair.
3. We would offer free repair only when the damages are caused by technical deficiencies of the product itself. Man made errors, or to say the mishandling damages are not included.
4. The purchasing date is the invoice date (if the customer has no invoice, it depends on the delivery date).
5. If the models have been stopped producing, we only do the function repairing.

Warranty Void Cases:

1. The fault caused by improper use.
2. The damage caused by improper storage or natural disaster.
3. Without the consent of our company, the customer disassemble, repair and modify the product.

After-sales service:

1. Service Purpose: Serve the customer, satisfy the customer, the satisfaction of the attitude, perfect of the technology.
2. Service Goal: Service and quantity to win customers' satisfaction.

Note: Our company reserves the right to final explanation.

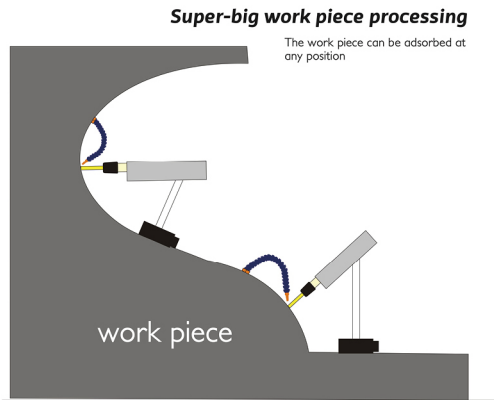

Super-big work piece can be adsorbed on directly, and the head position is adjustable.

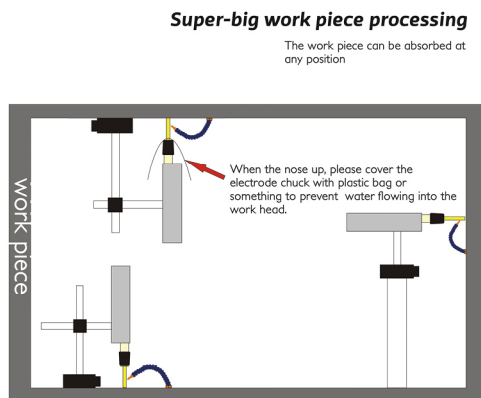

When processing the inner wall of big work piece, the work head can be adsorbed on the side part of the work piece.

Note: When horizontal processing, pay attention to the water proof work of the work head.

## Profile

With the rapid development of automation equipment, high demand of products' precision and extensive usage of difficult-to-cut materials in machining, tools broken into work pieces has heavily affected the defective rate of products. The common methods of removing broken taps and drills are smashing items by hand, screwing them out after welding, or even acid corrosion and flame cutting, which contribute to low efficiency and damage to work pieces.

The newly innovated machine SFX-4000B is based on the technique of HHJ series. It can fast remove broken taps, drill, drift, screw, plug gauge, etc., without damaging to the work piece, easily process on work pieces at any size, especially effective for large machine tools. The integral construction of this machine left a space for storage at the bottom of the power box which is convenient for managing the attachments. With a high efficiency in processing, it could remove broken tap, screw and is especially good at processing mark.

Please feel free to contact us if you got any problem in processing or would like to share your valuable experience.



**Video QRCode for Operation**

## High Power EDM Machine SFX-4000B Tech. Specification

Input Voltage (V)	AC110V/220V, 50Hz/60Hz (Vary from different countries requirements)
Input Power (W)	300-3000
Output Voltage (V)	DC70-80V
Working Liquid	Tap water (Pure water / distilled water is better. )
Electrode Chuck Diameter	2-13mm
Max Travel of Working Head (mm)	70
Short Hole(Dep. ≤ 10mm) Processing Speed(mm/min) Material: Quenched Steel	≈ 2                      ≈ 1 Electrode φ 5    Electrode φ 12
Machine Size (L*W*H mm)	420*220*370
Work Head Size (L*W*H mm)	DK8 315*50*50
Pump Size (L*W*H mm)	60*45*55
Net Weight (kg)	22

### Non-vertical processing

Build a diversion channel with a piece of rag or tape.

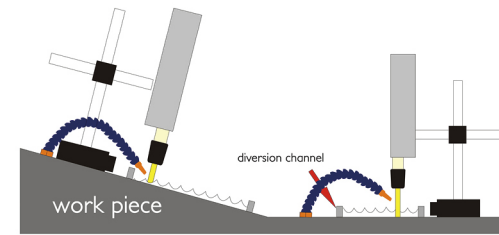

Vertical processing on big work piece. Adsorb the base directly on the work piece, and build a diversion channel under the work head to drain coolant outside.

### The desktop unit is suitable for small work piece processing

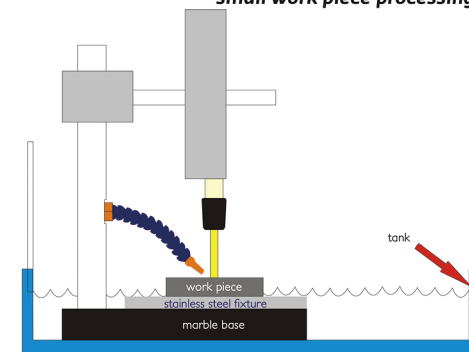

Choose desktop unit to fix the work-piece. It could process small work piece. Put the desktop unit into the tank to avoid the coolant losing.

## IX. Selection of Stepper

Open the stepper button, the indicator would light up. The high power mode is suitable for the electrodes of 6-18mm diameter. Turn the current adjustment knob, the current can be adjusting. Close the stepping switch, it is the low power mode. This mode is suitable for the electrodes of 2-5mm diameter and the current could not be adjusted.

## X. How to Clamp the Electrode to Avoid Work Piece being Damaged

During electric discharge machining, the negative pole (blue line) should connect the tool electrode while the positive pole (red line) should connect the work piece. This method could reduce the consumption of tool electrode and decrease the surface roughness.

As there is a slight gap between alligator and terminal, the electric discharge may damage the work piece. To avoid this problem, you could choose a threaded hole near the processing point to screw on a screw or choose a hole near the processing point to inset a pin, then clamp the screw or pin. Or clamp a position which is unimportant. The clamping distance of positive and negative poles should maintain the principle of proximity to reduce the current losses in transmission. Make sure the work piece is well fixed, the electrode alignment of the central axis of the work piece is an important assurance to the processing quality.

## XI. The Schematic Diagram of EDM Processing Method

Portable EDM machine applies a magnetic base and a cross stand to support the head, it can be placed at any position, adjust the processing direction comprehensively. It can be applied on any size of work-pieces. Here are the schematic diagrams of processing methods:

## I. Functions and Features

1. SFX-4000B abides by the principle of spark erosion to remove broken tools, no direct contact. Thus, no external force and damage to the work pieces.
2. Excellent Structure: It is convenient to carry due to small size and light weight, and shows its special superiority for large work pieces. Working head is separated from the machine and could rotate in any direction, which is helpful for complex machining.
3. Portability: Light weight. Small size. Carrying handle on the top of the power case.
4. Convenient Operation: The magnetic base could be adsorbed on work pieces to finish processing easily.
5. Accurate Positioning: Work Head can be installed on desktop workbench or aluminum workbench, which is convenient for fast setting and precise positioning, and is suitable for batch processing.
6. Easy Maintenance: MCU Controller and Function Modularization are utilized to guarantee stable performance and easy maintenance.
7. Economical and Convenient: The working liquid is ordinary tap water. Power consumption is moderate.
8. Wide Processing Range: Broken taps and drills (conductive material) above  $\phi 2\text{mm}$  ( $\phi 2\text{mm}$  is included).
9. Long Working Hours: A cooling fan installed ensures the ventilation, which keeps the machine working continuously.

## II. Components of EDM

Working part: Power box, operation panel, work head, water pump, magnetic base.

Power box: The power box of SFX-4000B is portable designing unit. The carrying handle on the top of power box is good for carrying.

Assist devices: Power cable, high-frequency cable, servo cable, water pipe, Universal Pipe, electrode chuck, adapter sleeve, etc. Consumables: brass bar, hexagon electrode, brass sheet.

**Diagrams of Each Part:**

**1. Work Head:**

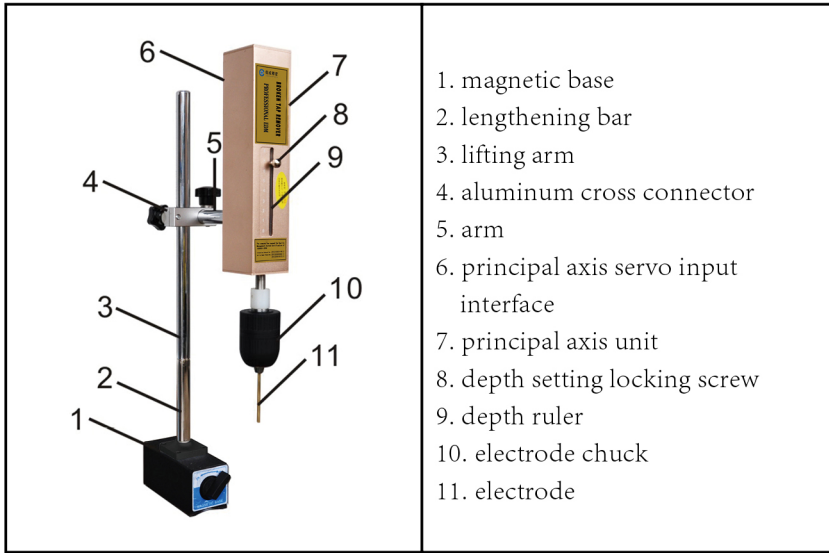

**Fig.1 Work Head**

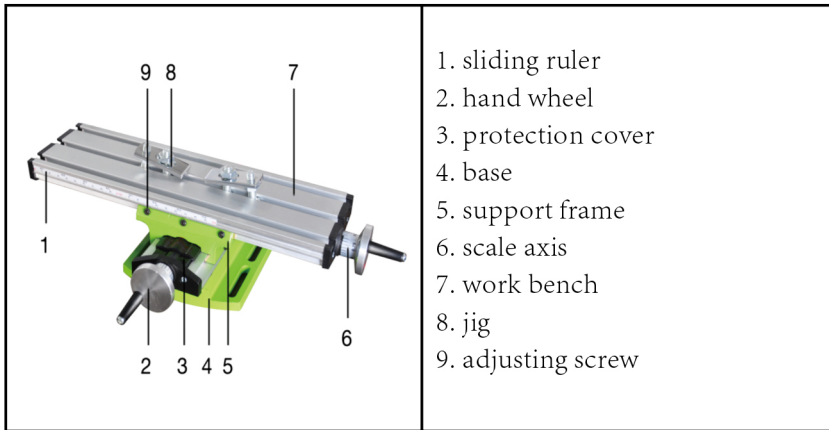

**Fig.2 Aluminum Jig and Fixture (Optional)**

**VIII. How to Remove Broken Tap, Drill, Screw etc. Out**

The central part for tap, drill is solid. We could remove tap or drill by smashing the central part with the brass rod. When removing tap with bigger size central part, cut the central part into two pieces with sheet electrode, or cut the four corners of the tap. In actual operation, when processing in a specific depth, turn back the work-head, rap the debris with chisel and use tweezer or magnet to remove the debris. By doing this, will decrease the discharge area and improve the working efficiency. (Figure 1)

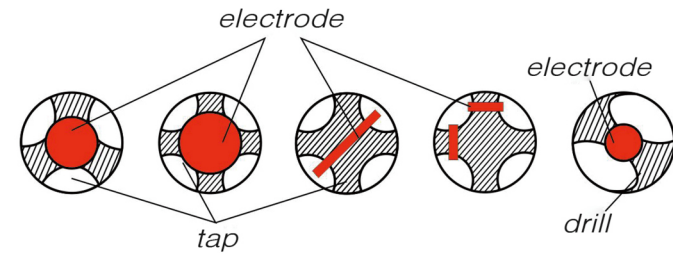

(Fig. 1)

When the diameter of the screw is too big or its strength grade is over 8.8, general processing method is unsuitable. You can process a groove of 2-3mm depth with a sheet electrode. Then unscrew it with a screwdriver or hexagon spanner. If the processing position is too deep for general screw extractor, the hexagon spanner would help. (Figure 2)

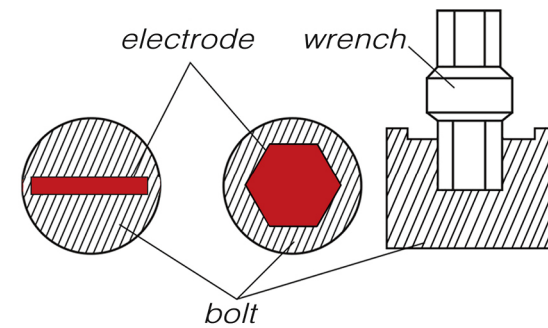

(Fig. 2)

**Reference Table of Electrode Size**

Broken Items	Size	Electrodes Recommended	Remarks
Tap	M3	$\phi$ 1.5	The diameter of electrodes should be half of the broken taps
Tap	M4	$\phi$ 2.0	
Tap	M6	$\phi$ 3.0	
Tap	M8	$\phi$ 4.0	
Tap	M10	$\phi$ 5.0	
Tap	M12	$\phi$ 6.0	
Tap	M14	$\phi$ 7.0	
Tap	M16	$\phi$ 8.0	
Tap	M20-30	10*2 Sheet electrode	
Screw	M3-20	Method Recommended: drill a straight, square or hexagonal groove, and remove it with matching tools.	

**2. Power Box**

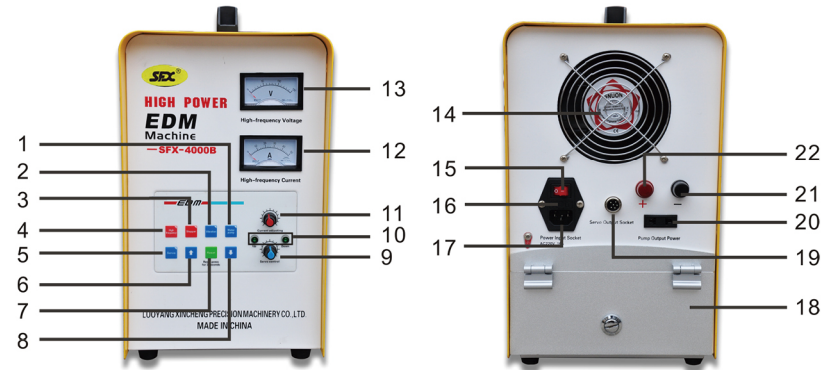

- 1. Water Pump
- 2. Vibration
- 3. Stepper
- 4. High Frequency
- 5. Servo
- 6. Up
- 7. Reset
- 8. Down
- 9. Servo Control
- 10. Indicators
- 11. Current Adjusting
- 12. High-frequency Current
- 13. High-frequency Voltage

- 14. Fan
- 15. Power Switch
- 16. Protective Tube
- 17. Power Socket
- 18. Storage Box
- 19. Servo Output
- 20. Pump Power Output
- 21. Negative Armature Terminal
- 22. Positive Armature Terminal

### III. Operation Notices

#### 1. Operating Steps:

##### 1.1 Working part assembly:

(1) Place working part at a proper position accordingly, put the magnetic base on a flat workbench to guarantee the stability, turn on the magnetic switch.

(2) Loosen screw of the cross connector, adjust vertical position of the spindle unit, so that the distance between electrode tip and work piece would be controlled into 2-3mm.

##### 1.2 Circuit conjunction:

(1) Insert the high-frequency power cord and servo control plug into Armature Terminal 21, 22 and 19 on the back of the power box respectively, make sure they are well connected.

Note: Pay attention to the "+" (red) and "-" (blue) Armature Terminal.

(2) insert the power cord plug into power socket (17), then connect power supply. Make sure the ground electrode is grounded.

(3) As for outputs of the high-frequency power, connect the red alligator clip (positive pole) to the work piece, the other line (negative pole) to the spindle by electrode chuck.

##### 1.3 Connection of water pipe:

Connect the water outlet of external water pump with universal joint and set the universal joint at the machining parts, then align the processing point. Put the water pump into the tank, ensure that the water pump submerged in the liquid to avoid the pump damaging.

#### 2. Processing Steps:

2.1 Turn on the power switch (15), adjust position and height of the spindle, make sure the electrode and broken items are coaxial to avoid damaging the work piece.

2.2 After adjusting the position, press the water pump button (1). Press high-frequency button (4) and servo button (5) one by one when water flows from

### VI. Selection of Electrode Materials and Work Liquid

As discharge machining material, easy processing and electrical erosion resistance materials with good conductivity, high melting point are usually being used as tool electrodes, such as copper, graphite and copper-tungsten alloy, etc. Generally, the economic brass which works well is priority being used in removing broken taps, etc.

The working liquid is dielectric medium, which plays the role of cooling and chip removal. So the dielectric medium with low viscosity, high flash point and stable performance are usually being used, such as pure water, kerosene, etc. When processing aluminum parts, kerosene could be used as the working liquid to prevent oxidation of aluminum. For iron or steel parts, clean tap water could achieve good effect.

### VII. Selection of Electrode Size

Electrode discharge area is generally about 0.3mm~1mm diameter larger than themselves. For example, an electrode of 3mm diameter could process a hole of 3.3mm~4mm diameter. The electrode should be chosen according to the actual processing conditions to avoid injury to thread and the discharge area should be considered.

Selection of electrodes for removing general broken objects should reference following table:



## V. Failures and Solutions

Failures	Failure Reasons and Solutions
After turning on the machine, the spindle can not move.	<ol style="list-style-type: none"> <li>1.The servo cord is not connected. Please connect the power line again.</li> <li>2.The spindle reach the upper limit and start the travel switch. Open the machine and press the reset button for 2-3 seconds to get the machine back to work.</li> <li>3.Something is wrong with the servo controller. Please contact us immediately.</li> </ol>
When the electrode touch the work piece. There is no electric spark.	<ol style="list-style-type: none"> <li>1.The high frequency cord are not connected or not connected well. Connect/ Reconnect the high frequency cord.</li> <li>2.Something wrong with the high frequency cord. Contact us immediately.</li> </ol>
The processing speed is good but the hole is not very deep, and the electrode consumption is very large.	<ol style="list-style-type: none"> <li>1.The polarity of the high frequency is reverse. Adjust the polarity of the high frequency cord.</li> <li>2.The machining parameter is unsuitable. Adjust the machining parameter.</li> <li>3.The diameter of the electrode is too small while the electric current is very large. Adjust the current switch and the servo knob to reduce the electric current.</li> </ol>
The processing is unstable, pointer of the ammeter swing back and forth with a large amplitude.	<ol style="list-style-type: none"> <li>1.The servo knob is not at the best position. Adjust the servo knob.</li> <li>2.The work piece or electrode are not clipped well. Replace the work piece stably and clamp the electrode tightly.</li> <li>3.The water is not flowing at the best position. And the water is not enough. Adjust the position of water pipe.</li> <li>4.When processing to a certain depth, the chip removal is not good which results in the current unstable. Please turn the "servo adjusting" knob counterclockwise to improve discharging gap.</li> </ol>
There is electric arc during processing	<ol style="list-style-type: none"> <li>1.Choosing of stepper is incorrect. Close the stepper if the electrode diameter is less than 6mm.</li> <li>2.The current adjusting is unsuitable. Please adjust to the suitable current.</li> </ol>

water pipe. The spindle decline and the corresponding indicator light up. If the spindle doesn't decline, please press the reset button (7). When spindle reach the position of discharge gap, up and down indicators flash alternately, and the processing begins. At this moment, you can adjust the discharge gap by turning the servo adjusting knob (9) and control the current by turning the current adjusting knob (11) to control the processing speed. Referring to the table of measured data and the diameter of your electrode to decide opening the stepper (3) or not.

### 3. Usage of Up " ↑ " and Down " ↓ " Button

After pressing the servo button, the system default decline. Press the up " ↑ " button the spindle would go up while press the down " ↓ " button it would go down.

### 4. Usage of Reset Key

When work head reach the default depth, spindle would start the trip switch and fallback automatically. At the same time, power box would alarm. Then you can press the reset button to stop the alarm and get the work head back to work.

When spindle fallback to the upper limit, it would stop, but the alarm won't. Then you should press the reset button to get it back to work.

### 5. Usage of Vibration Button

During processing, press vibration button to start vibration motor in the work head. The vibration motor would oscillate the electrode. It would double the processing efficiency. When processing high precision holes, the oscillation would reduce accuracy. Then the vibration should be closed. P.S.: The vibration button only works when the servo is turning on. If you turn off the servo, the vibration would stop too.

### 6. Shutdown Procedures

6.1 Press the high-frequency button (4), the corresponding indicator would light off and the high-frequency is closed.

6.2 Press the up " ↑ " button (6), the up indicator would light up while the spindle turning up. Wait until the electrode left the work piece and press



the servo button (5), then press the water pump button (1) to light off the corresponding indicator.

6.3 Turn off the power switch 15.

#### **IV. Attentions**

1.The external water pump is a precision part, please be careful when using.

1.1 The working liquid must be clean water or special cutting liquid. The inlet pipe should install the filter.

1.2 At the first time, you should wait for about 3-5 seconds, after there is no air in the pipe, the water will flow out.

1.3 You should always check the liquid. Make sure the filter is below the liquid level, if there is no water in pipe when the pump is working, it is dangerous for the pump.

1.4 When the temperature is below zero, if you do not use the machine, please guarantee no water in pump to avoid being broken.

2. In case the working liquid is kerosene (the flashing point is above 70 centigrade), PLEASE DO NOT USE THE PUMP (the pump will be broken when it meets kerosene). The level of working liquid should be more than 20mm higher than the work piece, in case, the oil level is too low, causing fire, and also please be ready for fire.

3. When the machine is working, please do not touch the electrode. After processing, please make the high frequency output "+、-" pole touch each other to make short circuit discharge, which could prevent electric shock.

4. Avoid being used in heat-treatment shop, electroplating workshop and the field with corrosive materials or a large amount of dust. Please pay attention to protect the machine from water and protect the circuit from being damaged by corrosive substance. Store properly after use to protect it from foreign object. Prohibits work in hazardous environments, such as the fire ban area.

5.When power-off, please do not leave the servo knob remaining at the upper or lower limit position.



6. The machine is equipped with precision electronic components, avoid bumping it when moving. Before using, do some shock prevention, keep away from stamping equipment or planer which could cause vibration and shock. Cut off the main power after use, clean up and keep it properly.

7. The electric conductivity of work piece and the electrode clamping have great influences on the processing efficiency. Before processing, clean up the rust or oxide film of the work piece to get better conductivity. Clip the alligator clip in a proper position to keep the electrode and alligator clip nearby, and meanwhile keep the work-piece from damaging by electric current.

8. After a period of using, the spindle should be lubricated from the chute part to keep well operation of the head.

9. To avoid accidents, non professionals do not attempt to open the power box to repair.